

Round-trip System Available to Measure Path Length Variation in Korea VLBI System for Geodesy

Hongjong Oh¹, Tetsuro Kondo², Jinoo Lee¹, Tuhwan Kim¹, Myungho Kim³,
Suchul Kim³, Jinsik Park³, Hyunhee Ju³

¹⁾ *Ajou University*

²⁾ *National Institute of Information and Communications Technology and Ajou University*

³⁾ *National Geographic Information Institute*

Contact author: Hongjong Oh, e-mail: stockoh@ajou.ac.kr

Abstract

The construction project of Korea Geodetic VLBI officially started in October 2008. The construction of all systems will be completed by the end of 2011. The project was named Korea VLBI system for Geodesy (KVG), and its main purpose is to maintain the Korea Geodetic Datum. In case of the KVG system, an observation room with an H-maser frequency standard is located in a building separated from the antenna by several tens of meters. Therefore KVG system will adopt a so-called round-trip system to transmit reference signals to the antenna with reduction of the effect of path length variations. KVG's round-trip system is designed not only to use either metal or optical fiber cables, but also to measure path length variations directly. We present this unique round trip system for KVG.

1. Introduction

The round-trip system used in the frequency distribution system is a system to transmit a reference frequency signal to a remote place separated by a few tens to hundreds of meters from a signal source such as an H-maser frequency standard while diminishing the effect caused by the change of transmission cable length. The reference frequency distribution system supplies reference frequency (10 MHz or 100 MHz) and timing signals (1 PPS) generated by the H-maser frequency standard to devices that require these reference signals. Such devices are located not only in the observation room close to the H-maser frequency standard, but also in the receiver cabin of the antenna separated from the observation building by several tens to hundreds of meters. Therefore, a system is needed to transmit reference signals to the receiver cabin in a stable manner. Buried cables or fibers at a depth of 1–2 m offer the greatest stability of the transmission path to the antenna. Path length variations are directly related to the accuracy of geodetic VLBI measurements, so they should be kept as small as possible. The effect of these path length variations can be diminished by using a round-trip system as a reference frequency transmitting system.

2. Principle of Round-trip System

Figure 1 shows a schematic block diagram of a round-trip system. The system consists of a reference signal generator, an oscillator, and transmission cables (metal co-axial cable).

A signal with a frequency of $f_0 (= f_1 + f_2)$ is generated by H-maser frequency standard and put into the system at A. The signal is mixed with signal f_2 transmitted from B to form signal

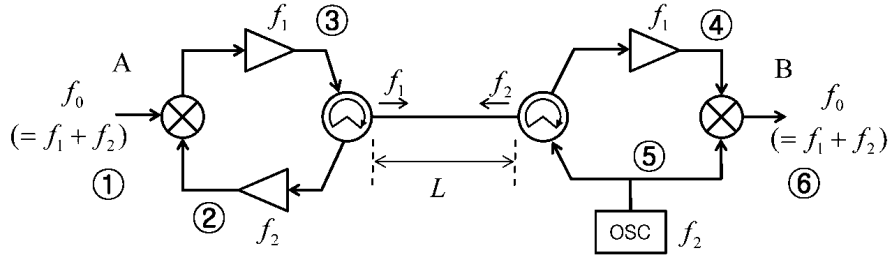

Figure 1. Schematic block diagram of a round-trip system.

f_1 . This signal is transmitted to B. At B, signal f_1 is mixed with signal f_2 , which is a locally generated signal, to form the sum frequency $f_1 + f_2 (= f_0)$. This is a reference signal transmitted to B. Signal f_2 is also transmitted to A.

The principle of operation can be expressed as follows. Signal at ① can be expressed as

$$S_1 = (\sin 2\pi(f_1 + f_2)t + \phi_0) \quad (1)$$

$$S_5 = \sin(2\pi f_2 t + \phi_{osc}) \quad (2)$$

therefore signal at ② is given by

$$S_2 = \sin\left(2\pi f_2\left(t - \frac{L}{v}\right) + \phi_{osc}\right) \quad (3)$$

where v is the velocity of signal transmission in a cable. Signal at ③ is a low-pass filtered signal of products of S_1 and S_2 , which is

$$S_1 \cdot S_2 = (\sin 2\pi(f_1 + f_2)t + \phi_0) \cdot \left(\sin\left(2\pi f_2\left(t - \frac{L}{v}\right) + \phi_{osc}\right)\right) \quad (4)$$

Hence

$$S_3 = \frac{1}{2} \cos\left(2\pi f_1 t + 2\pi f_2 \frac{L}{v} + \phi_0 - \phi_{osc}\right) \quad (5)$$

Therefore signal at ④, is given as

$$S_4 = \frac{1}{2} \cos\left(2\pi f_1\left(t - \frac{L}{v}\right) + 2\pi f_2 \frac{L}{v} + \phi_0 - \phi_{osc}\right) \quad (6)$$

Signal at ⑥ is a high-pass filtered signal of products of S_4 and S_5 .

$$S_4 \cdot S_5 = \frac{1}{2} \cos\left(2\pi f_1\left(t - \frac{L}{v}\right) + 2\pi f_2 \frac{L}{v} + \phi_0 - \phi_{osc}\right) \cdot \sin(2\pi f_2 t + \phi_{osc}) \quad (7)$$

$$S_6 = \frac{1}{4} \sin\left(2\pi(f_1 + f_2)t + \phi_0 - 2\pi(f_1 - f_2)\frac{L}{v}\right) \quad (8)$$

Note that the phase of an oscillator does not appear in the output. We focus on two components, which are frequency and length of cables. The phase difference between signals A and B is given by comparing Eq (1) and (9) as

$$\phi = 2\pi(f_1 - f_2) \frac{L}{v} \quad (9)$$

Hence the change of cable length from L to $L + \Delta L$ results in the change of phase as follows,

$$\Delta\phi = 2\pi(f_1 - f_2) \frac{\Delta L}{v} \quad (10)$$

When a signal is transmitted directly at $f_0 = f_1 + f_2$, the phase change due to cable length change is given by

$$\Delta\phi = 2\pi(f_1 + f_2) \frac{\Delta L}{v} \quad (11)$$

Therefore phase variation due to the cable length change can be suppressed to the level of $(f_1 - f_2)/(f_1 + f_2)$ compared with the case of that signal being directly transmitted at a frequency $f_0 (= f_1 + f_2)$. The round-trip system developed for the VERA project, which is the Japanese VLBI project dedicated to astrometry, adopts $f_1 = 690\text{MHz}$, $f_2 = 710\text{MHz}$ (i.e., f_0 is 1400 MHz). In this case the change of phase is suppressed by $|690 - 710|/1400 = 0.014$. Phase variation is suppressed about 1% level compared with the case of direct transmission.

3. Detection of Phase Variation

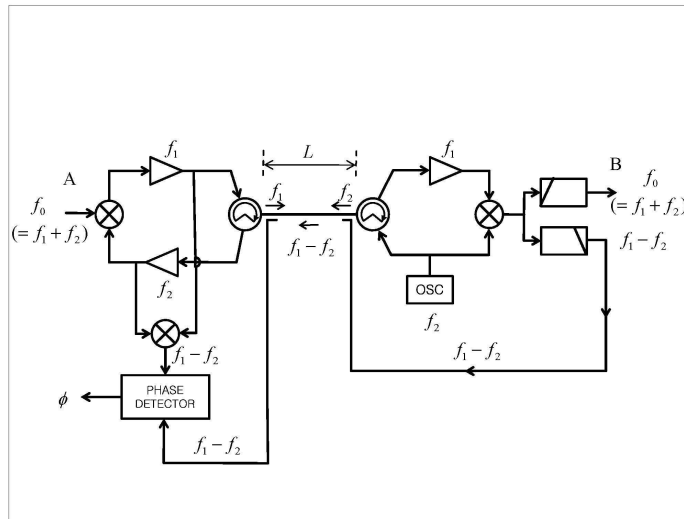

Figure 2. Schematic block diagram of round-trip system designed for measurement of phase variation.

A round-trip system as described in Section 2 is the system dedicated to suppress phase variation due to cable length change as much as possible. Therefore it does not intend to measure the phase variation itself.

In order to monitor phase change directly, we consider the system shown in Figure 2. At side B, signal $f_1 - f_2$ is generated. This signal is a low-pass filtered signal of products of S_4 and S_5 in the previous section (in this section written as S_{45L}).

$$S_{45L} = -\frac{1}{4}\sin(2\pi(f_1 - f_2)t - 2\pi(f_1 - f_2)\frac{L}{v} + \phi_0 - \phi_{osc}) \quad (12)$$

This signal is injected to a metal cable through a directional-coupler then transmitted to A. $S_{45L(A)}$ thus becomes

$$S_{45L(A)} = -\frac{1}{4}\sin(2\pi(f_1 - f_2)t - 2 \cdot 2\pi(f_1 - f_2)\frac{L}{v} + \phi_0 - 2\phi_{osc}) \quad (13)$$

At side A, the same frequency signal is generated independently of S_2 and S_3 in the previous section. The signal is a low-pass filtered signal of the product of S_2 and S_3 . Therefore it is expressed as follows,

$$S_{23L(A)} = -\frac{1}{4}\sin(2\pi f_1 - f_2 t + 2 \cdot 2\pi f_2 \frac{L}{v} + \phi_0 - 2\phi_{osc}) \quad (14)$$

Hence the phase difference between S_{23L} and $S_{45L(A)}$ is given by

$$\phi = 2 \cdot 2\pi f_1 \frac{L}{v} \quad (15)$$

Therefore the change of cable length from L to $L + \Delta L$ results in the change of phase as follows,

$$\Delta\phi = 2 \cdot 2\pi f_1 \frac{\Delta L}{v} \quad (16)$$

This corresponds to the double of phase change at frequency. In the case of VERA, the frequency was set to $f_1 = 690MHz$, $f_2 = 710MHz$, and $f_1 - f_2 = 20MHz$. In the case of KVG, it was set to $f_1 = 689.9MHz$, $f_2 = 710.1MHz$, and $f_1 - f_2 = 20.2MHz$. This frequency signal can be sampled by using the K5/VSSP32 VLBI sampler, which has a maximum sampling frequency of 64 MHz. We will reduce the sampling frequency; we can use 2 MHz, 1 MHz, and even 500 kHz as a sampling frequency. So that phase can be monitored digitally by using this sampler.

4. Application to KVG System

In the KVG system, we develop a round-trip system that can use both metal cable and optical fiber (not simultaneously but exclusively). Our plan is that the manufacturing will be finished in June 2010 and that we will proceed with testing in July. Figure 4 shows block diagrams of the transmitter and the receiver of the round-trip system under consideration.

References

- [1] Tetsuro Kondo, Conceptual Design of Backend System and Ground Surveying System for Korea VLBI System for Geodesy (KVG), Ajou University, 2009.
- [2] Tetsuro Kondo, Round trip system, KVG technical report, 2010.

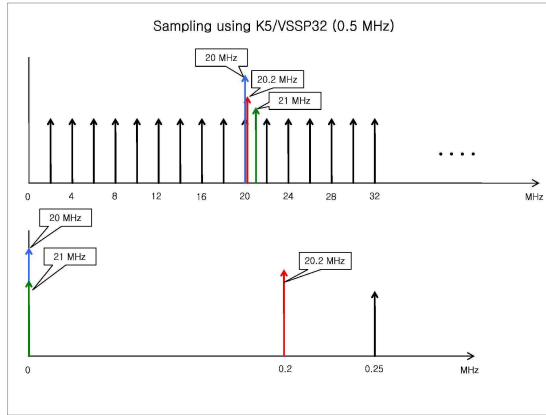

Figure 3. Sampling using K5/VSSP32(0.5 MHz).

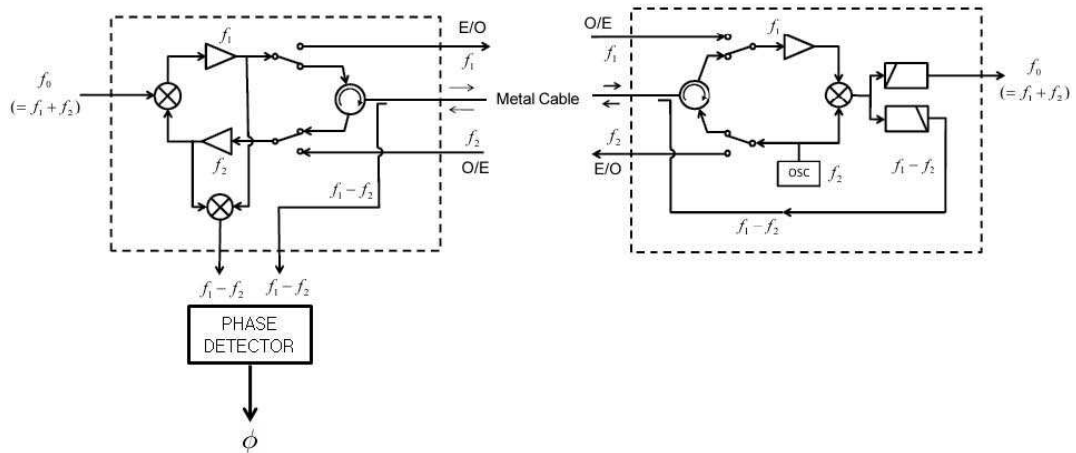

Figure 4. Round-trip system for KVG.